



**Temporarily Installed
Suspended Access Equipment**

OPERATION MANUAL

For ZLP Series

Temporarily Installed Suspended Platform

INSTALLATION OPERATION

MAINTENANCE



**NOTE: READ OPERATION MANUAL CAREFULLY BEFORE OPERATING
TEMPORARILY INSTALLED SUSPENDED ACCESS EQUIPMENT**

Content

| | |
|---|-----------|
| 1. Brief Description..... | 1 |
| 2. Main Parameters..... | 1 |
| 3. Main Structure and Operation Principle..... | 4 |
| 3.1 Suspension Mechanism..... | 5 |
| 3.2 Suspended Platform..... | 7 |
| 3.3 Hoist..... | 8 |
| 3.4 Safety Lock..... | 8 |
| 3.5 Electric Control System..... | 9 |
| 3.6 Steel Rope..... | 11 |
| 4. Installations and Adjustment..... | 12 |
| 4.1 The Preparation before Installation..... | 12 |
| 4.2 Installation of Suspension Mechanism..... | 12 |
| 4.3 Installation of Suspended Platform..... | 13 |
| 4.4 Installation of Hoists, Safety Locks and Electric Control Box..... | 13 |
| 4.5 Adjustment of Rotating Direction of the Motor..... | 14 |
| 4.6 Connection Between Suspended Platform and Suspension Mechanism.... | 14 |
| 4.7 Special Notice..... | 14 |
| 5. Operation..... | 15 |
| 5.1 Checking and Adjusting after Installation..... | 15 |
| 5.2 Operation Procedure..... | 16 |
| 5.3 Safety Operation Regulations..... | 17 |
| 6. Common Failures and Troubleshooting..... | 19 |
| 7. Maintenance..... | 20 |
| 7.1 Daily Maintenance..... | 21 |
| 7.2 Daily Check | 21 |
| 7.3 Check Periodically..... | 21 |
| 8. Storage, Packing and Transportation..... | 22 |
| 9. Documents and Tool..... | 22 |
| 9.1 Documents attached..... | 22 |
| 9.2 Tools..... | 22 |
| 10. Attached Table and Figure..... | 22 |

1. Brief Description

ZLP series temporarily installed suspended access equipment is ideal equipment for building facade construction, decoration, cleaning and maintenance. And it is also widely used in elevator installing, ship building and repairing, or in other works such as big-size tank, bridge, embankment and chimney.

It is easy for operation, flexible for moving, reliable in safety. Besides, it is not necessary to build scaffolding in the construction, the efficiency will be promoted and the cost will be reduced. Therefore, ZLP series versatile knock-down platforms provides workers safer, easier and more efficient platform access.

ZLP series temporarily installed suspended access equipments are conforming to the national standard GB19155-2003.

2. Main Parameters

Model description

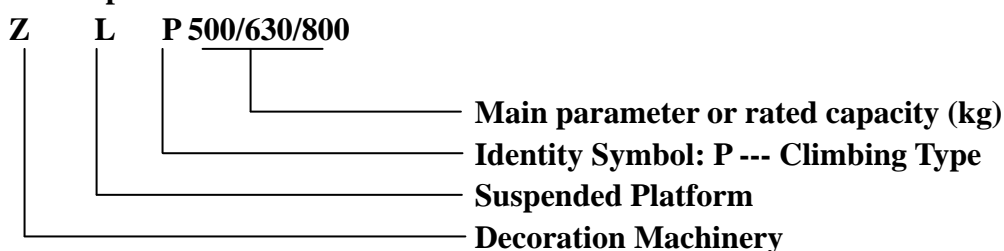

Table 1: Main Parameters for ZLP500

| Item | | Parameters | |
|----------------------|----------------------------|----------------|----------|
| Rated capacity | | 500 kg | |
| Rated speed | | 9.6 m/min | |
| Platform length | | 4 m~5m | |
| Steel rope | | 4T31 | |
| Hoist | Hoist model | LTD5 | |
| | Rated lifting force | 5 KN | |
| | Motor | Model | YEJ90L-4 |
| | | Power | 1.1 KW |
| | | Phase | 3 Phase |
| | | Speed | 1420 r/m |
| Brake force moment | 15 Nm | | |
| Safety lock | Configuration | Anti-tilting | |
| | Permission force of impact | 30 KN | |
| | Locking Cable Distance | <100mm | |
| | Locking Cable Angle | 3° ~8° | |
| Suspension mechanism | Front beam overhang | 1.3-1.7 m | |
| | Height adjustment | 1.365 -1.925 m | |

| | | | |
|---------------|--|--------------------------|--------|
| Weight | Lifting part (including hoist, safety lock and electric control system) | Steel Platform | 400 kg |
| | | Aluminum platform | 290 kg |
| | Suspension mechanism | | 310kg |
| | Counter weight | | 750 kg |

Table 2: Main Parameters for ZLP630

| Item | | Parameters | |
|-----------------------------|--|--------------------------|----------------|
| Rated capacity | | 630 kg | |
| Rated speed | | 9.6 m/min | |
| Platform length | | 6 m | |
| Steel rope | | 4T31 | |
| Hoist | Hoist model | | LTD6.3 |
| | Rated lifting force | | 6.3 kN |
| | Motor | Model | YEJ90L-4 |
| | | Power | 1.5kW |
| | | Phase | 3 phase |
| | | Speed | 1420 r/m |
| Brake force moment | | 15 Nm | |
| Safety lock | Configuration | | Anti-tilting |
| | Permission force of impact | | 30 kN |
| | Locking Cable Distance | | <100mm |
| | Locking Cable Angle | | 3° ~8° |
| Suspension mechanism | Front beam overhang | | 1.3-1.7 m |
| | Height adjustment | | 1.365 -1.925 m |
| Weight | Lifting part (including hoist, safety lock and electric control system) | Steel Platform | 450 kg |
| | | Aluminum platform | 330 kg |
| | Suspension mechanism | | 310kg |
| | Counter weight | | 900 kg |

Table 3: Main Parameters for ZLP800

| Item | | Parameters | |
|----------------------|---|-------------------|----------------|
| Rated capacity | | 800 kg | |
| Rated speed | | 8.3 m/min | |
| Platform length | | 7.5 m | |
| Steel rope | | 6*19W+IWS-8.6 | |
| Hoist | Hoist model | | LTD8 |
| | Rated lifting force | | 8 kN |
| | Motor | Model | YEJ100L1-4 |
| | | Power | 2.2 kW |
| | | Phase | 3 Phase |
| | | Speed | 1420 r/m |
| Brake force moment | | 15 Nm | |
| Safety lock | Configuration | | Anti-tilting |
| | Permission force of impact | | 30 kN |
| | Locking Cable Distance | | <100mm |
| | Locking Cable Angle | | 3° ~8° |
| Suspension mechanism | Front beam overhang | | 1.3-1.7 m |
| | Height adjustment | | 1.365 -1.925 m |
| Weight | Lifting part (including hoist, safety lock and electric control system) | Steel Platform | 600 kg |
| | | Aluminum platform | 430 kg |
| | Suspension mechanism | | 310kg |
| | Counter weight | | 1000 kg |

Notes: The voltage and frequency of home country is 380V, 50Hz. If your voltage and frequency are different, we will note here ___ V ___ Hz.

3. Main Structure and Operation Principle

ZLP series temporarily installed suspended access equipment consists of the components as below: hoists, safety locks, electric control system, suspended platform, suspension mechanism, counter weight, steel rope, etc (see figure 1 as below).

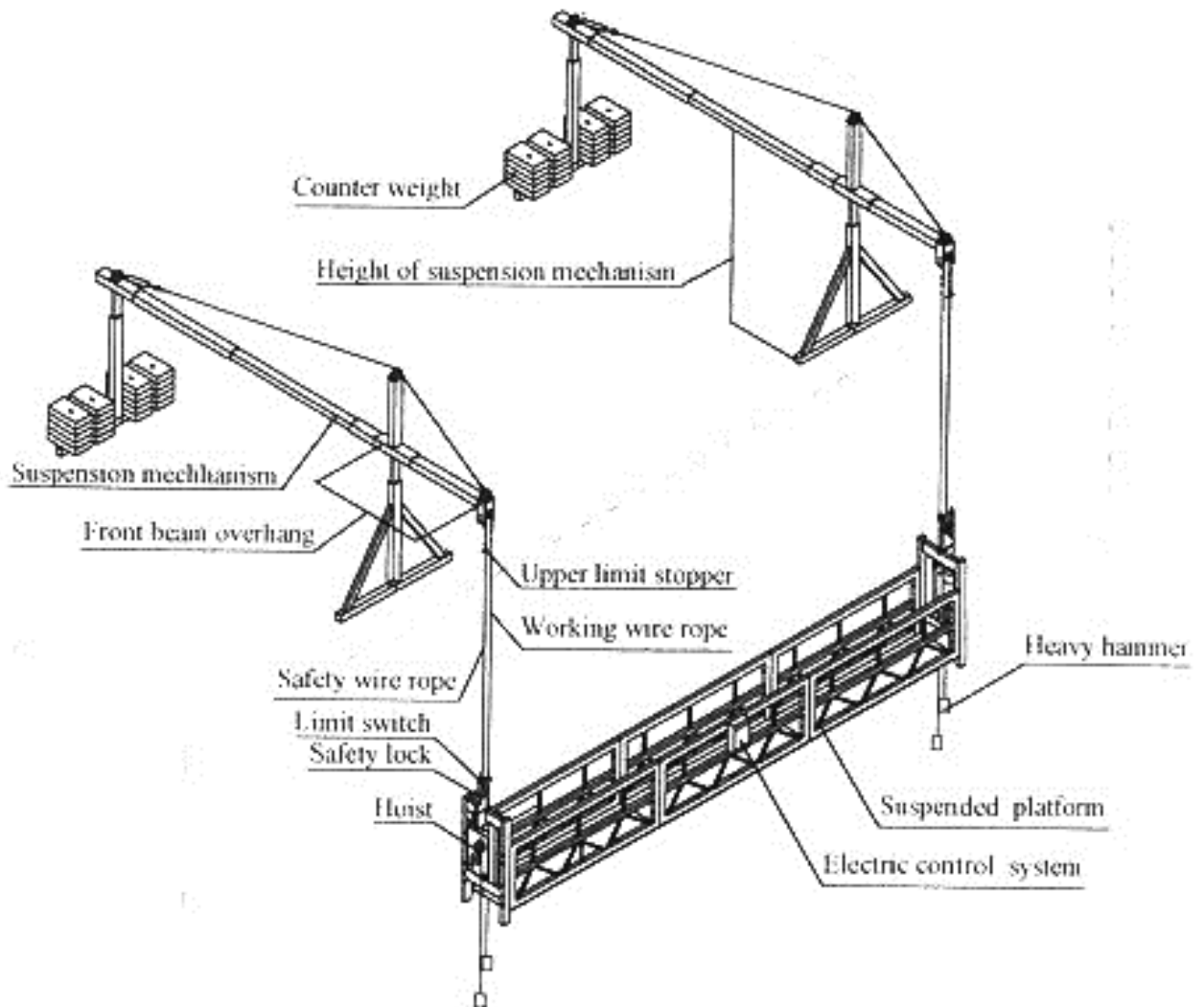

Figure 1: Temporarily Installed Suspended Access Equipment

3.1 Suspension Mechanism

The suspension mechanism is the heavy-duty steel frame structure fixed on the

top of the building as the supporting equipment. It is mobile, adaptable and easy to erect and dismantle.

3.1.1 The suspension mechanism (see figure 2 as below) consists of front beam (1), middle beam (4), rear beam (5), front base (2), rear base (6), upper column (8), tommy bar (3), counter weight (7) and reinforce steel rope (9) etc. The tommy bar is mounted on the front and rear base; the front and rear beams will be fixed through the tommy bar, the middle beam is fixed between the front and rear beam. The upper column is mounted on the tommy bar for fixing the reinforced steel rope and counter weight will be placed on the rear base. For details of structure, see attached figure 1: suspension mechanism on page 23.

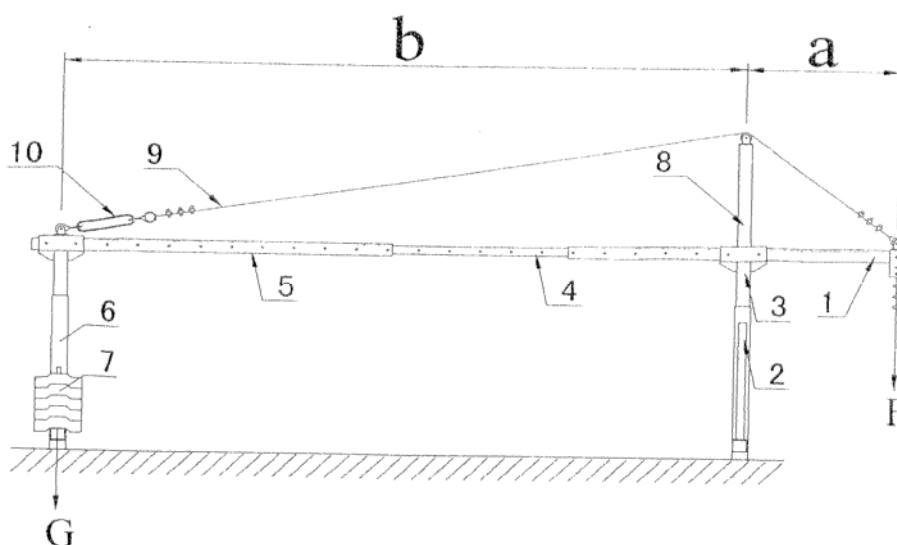

Figure 2: Suspension Mechanism

- | | | | |
|---------------------------|----------------|-------------------|-----------------|
| 1. Front beam | 2. Front base | 3. Tommy bar | 4. Middle beam |
| 5. Rear beam | 6. Rear base | 7. Counter weight | 8. Upper column |
| 9. Reinforcing steel rope | 10. Turnbuckle | | |

3.1.2 The configuration of the suspension mechanism shall meet the following formula:

$$n = \frac{G * b}{F * a} \geq 2$$

- n----- Safety coefficient against overturning;
- G----- Weight of counter weight in kg;
- a----- Front beam overhang in m;
- F----- Total weight in Kg of the platform, hoists, electric control system, safety lock, steel rope and rated load, plus wind pressure;
- b----- Distance in m between the front base and rear base.

Table 4: The Relation between Permissible Load and the variables as Working Height, Front Beam Overhang, Distance between the Front Base and Rear Base

| Model | Counter weight | Working Height | Front beam overhang | Distance between front and rear base | Permissible load |
|---------------|----------------|----------------|---------------------|--------------------------------------|------------------|
| ZLP500 | 750 kg | 50 m | 1.3 m | 4.6 m | 500 kg |
| | | | 1.5 m | 4.6 m | 500 kg |
| | | | 1.7 m | 4.4 m | 400 kg |
| | | 100 m | 1.3 m | 4.6 m | 500 kg |
| | | | 1.5 m | 4.6 m | 500 kg |
| | | | 1.7 m | 4.4 m | 350 kg |
| | | 120 m | 1.3 m | 4.6 m | 500 kg |
| | | | 1.5 m | 4.6 m | 500 kg |
| | | | 1.7 m | 4.4 m | 300 kg |
| | | 150 m | 1.3 m | 4.6 m | 500 kg |
| | | | 1.5 m | 4.6 m | 450 kg |
| | | | 1.7 m | 4.4 m | 250 kg |

Table 5: The Relation between Permissible Load and the variables as Working Height, Front Beam Overhang, Distance between the Front Base and Rear Base

| Model | Counter weight | Working Height | Front beam overhang | Distance between front and rear base | Permissible load |
|---------------|----------------|----------------|---------------------|--------------------------------------|------------------|
| ZLP630 | 900 kg | 50 m | 1.3 m | 4.6 m | 630 kg |
| | | | 1.5 m | 4.6 m | 630 kg |
| | | | 1.7 m | 4.4 m | 550 kg |
| | | 100 m | 1.3 m | 4.6 m | 630 kg |
| | | | 1.5 m | 4.6 m | 630 kg |
| | | | 1.7 m | 4.4 m | 500 kg |
| | | 120 m | 1.3 m | 4.6 m | 630 kg |
| | | | 1.5 m | 4.6 m | 630 kg |
| | | | 1.7 m | 4.4 m | 450 kg |
| | | 150 m | 1.3 m | 4.6 m | 630 kg |
| | | | 1.5 m | 4.6 m | 630 kg |
| | | | 1.7 m | 4.4 m | 400 kg |

Table 6: The Relation between Permissible Load and the variables as Working Height, Front Beam Overhang, Distance between the Front Base and Rear Base

| Model | Counter weight | Working Height | Front beam overhang | Distance between front and rear base | Permissible load |
|--------|----------------|----------------|---------------------|--------------------------------------|------------------|
| ZLP800 | 1000 kg | 50 m | 1.3 m | 4.6 m | 800 kg |
| | | | 1.5 m | 4.6 m | 800 kg |
| | | | 1.7 m | 4.4 m | 550 kg |
| | | 100 m | 1.3 m | 4.6 m | 800 kg |
| | | | 1.5 m | 4.6 m | 700 kg |
| | | | 1.7 m | 4.4 m | 460 kg |
| | | 120 m | 1.3 m | 4.6 m | 800 kg |
| | | | 1.5 m | 4.6 m | 680 kg |
| | | | 1.7 m | 4.4 m | 440 kg |
| | | 150 m | 1.3 m | 4.6 m | 800 kg |
| | | | 1.5 m | 4.6 m | 630 kg |
| | | | 1.7 m | 4.4 m | 400 kg |

3.2 Suspended Platform

Suspended platform is the workplace at heights for the workers. A modular system gives you the flexibility you need to mix and match sections to achieve different lengths. With caster wheel fitted underneath, the platform is easy to move.

Suspended platform (see figure 3 as below) consists of high and low balustrades, bottom plate and mounting frame for hoist. The mounting frames are fixed on the both ends of the platform and the hoists & safety locks should be fixed on the frame.

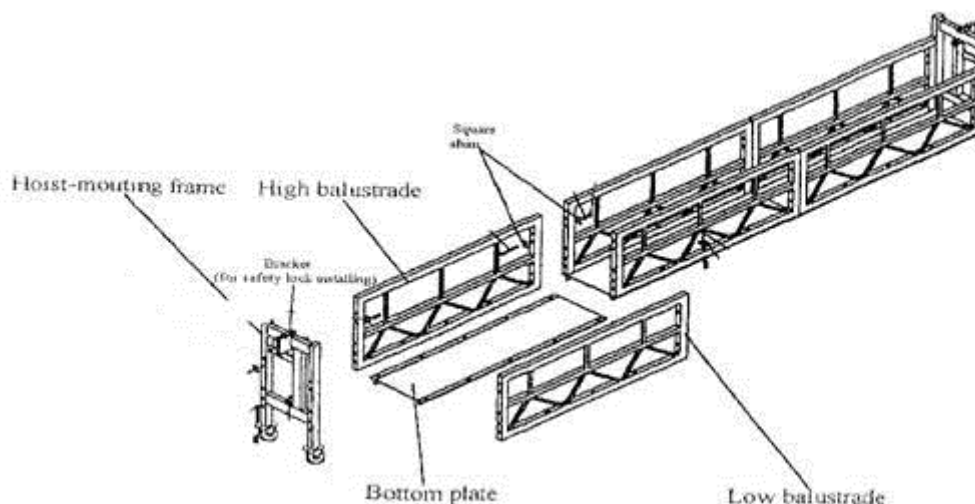

Figure 3: Suspended Platform

3.3 Hoist

The hoist is the powered unit for the platform with the climbing structure.

3.3.1 The hoist for ZLP series suspended platform is LTD5, LTD6.3 and LTD8. It

consists of electromagnetic brake motor, centrifugal speed limiter and dual speed reduction system , “α” cable-guiding system(LTD5 and LTD6.3) and “S” (LTD8) cable-guiding system. The hoist is driven by the electromagnetic brake three-phase asynchronous motor through the worm gear and a pair of reduced gears. The suspended platform will be moved upward and downward with the movement of the hoist.

3.3.2 The hoist is provided with automatic rope feeding function and operators just need to insert steel rope into the inlet of the hoist.

3.3.3 The electromagnetic brake of hoist motor is able to be auto-engaged to produce braking torque that stops and supports the suspended platform. In the event of power failure or emergency, the manual descending device can be used to prompt the suspended platform to slide downwards at even speed.

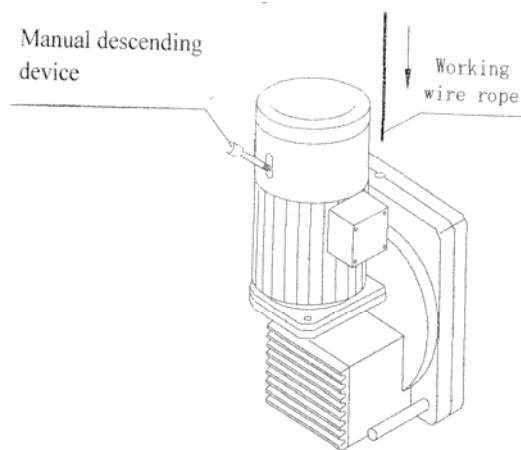

Figure 4: LTD 5 and LTD6.3 Hoist

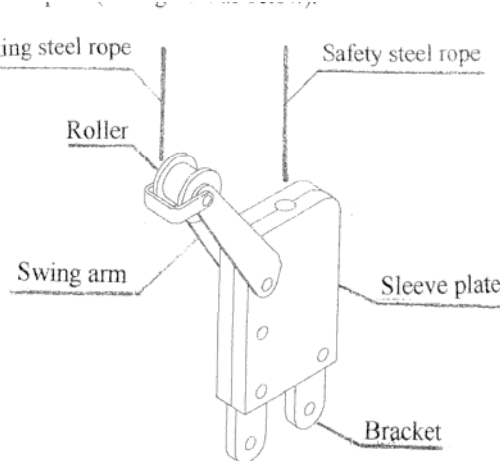

Figure 5: LSB30 II Safety Lock

3.4 Safety Lock

Model LSB30 II anti-tilting safety lock is the safety-protecting device for the suspended platform. When the working steel rope is broken or the suspended platform is inclined to certain angle, the safety lock will be actuated to lock the safety steel rope to prevent the suspended platform from falling down.

3.4.1 The anti-tilting safety lock consists of parts as rope clip, sleeve plate, torsion spring, bracket, swing arm and roller. It is so arranged that the working steel rope is put against the roller on the swing arm to make the rope clip open and allow the smooth pass of safety steel rope. If the suspended platform tilts to its limits or working steel rope break, the pressure on the swing arm of safety lock will reduce or impair. The safety rope clip swiftly closes and locks safety steel rope to prevent suspended platform from dropping or tilting by the friction as that in between torsion spring, rope clip and steel rope. When anti-tilting safety lock is applied, the tilt angle of suspended platform should be 3 °~8°.

3.4.2 The safety lock is marked by factory for the first time. After the first marking is

effective, the professional technician should conduct maintenance and service at an interval of 6 months and remark at the end of 6 months.

3.5 Electric Control System

The electric control system consists of electric control box, electromagnetic braking motor and handle switch etc. The up and down movement of suspended platform is controlled by two electromagnetic braking motors (see figure 6 as below).

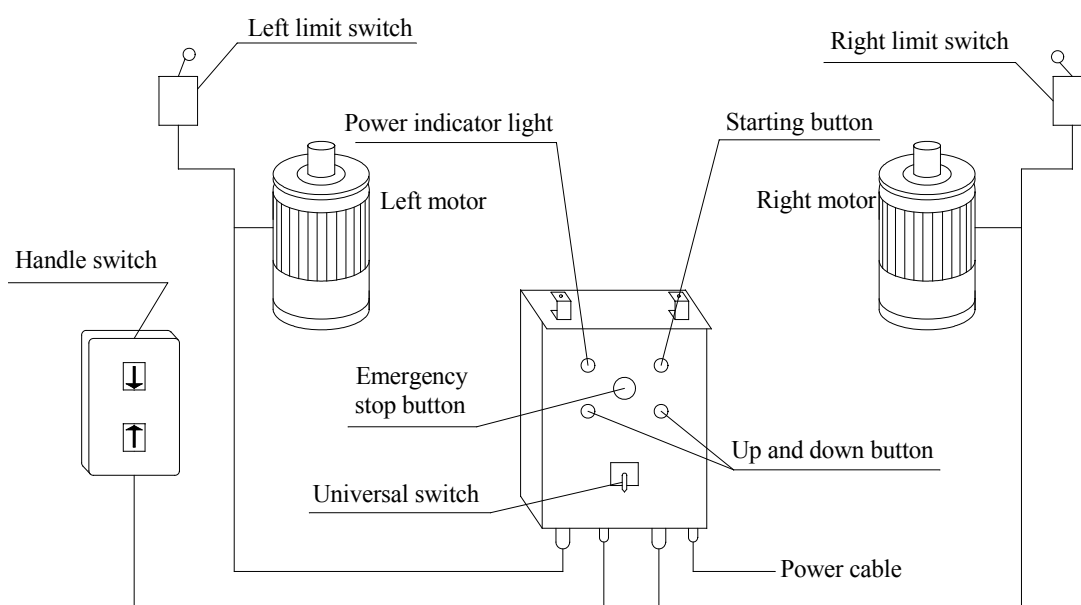

Figure 6: Electric Control System

The electric control box is used for the control of the up and down movement of the suspended platform. The main elements are mounted onto an isolated plate and the universal switch, power indicator light, starting button and emergency stop button are fixed on the panel.

3.5.1 The schematic diagram and wiring diagram see attached figure on page 30 and page 31.

3.5.2 The main electric elements see table 3 next page.

Table 3: List of Electric Elements

| Code | Name | Specifications | Remarks |
|------|------|----------------|---------|
|------|------|----------------|---------|

| | | | |
|------------------------------|------------------------------------|--|-----------------------|
| KM1,2,3 | AC contactor | CJX1-22/22 36V | |
| QF1 | Power leakage breaker | DZ47LE-32 In=25A(20A) I Δ n=30ma | 3-phase, 4-wire |
| QF2 | Miniature circuit breaker | DZ47-60 In=2A | Single-phase |
| TC | Control transformer | BK-100 380V/36V | |
| FR | Thermal overload relay | JR36-20/3 5A | |
| QC | Universal switch | LW5D-16/3 | Customized |
| SB1 | Starting button | LA19-11 | |
| SB3,4 | Control button | LA19-11 | |
| SB2 | Control button | COB61 | |
| STP | Emergency stop button | LAY3 | Self-lock |
| U1,2 | Rectifier for brake | | Integrated with motor |
| HL | Power indicator light | ND1-25 36V | |
| SL1,2 | Limit switch (or travel switch) | JLXK1-111(YBLX-K1/111) | |
| XP1,2 XS1,2 | 10-core plug | P32K11Q | |
| XP3, XS3 | 15-core plug | P32K9Q | |
| HA | Alarm bell | UC-4 36V 55mm | |
| YB1,2 | Electromagnetic brake | | Integrated with motor |
| FU1,2 | Fuse | 2A | |

3.5.3 The principle of electric control is as below:

- a. Power supply: the power supply adopts 3-phase and 5-wire system in which the 5-core cable is going through L1 power socket to control box, which is powered on by 3-phase leakage breaker. L4, L5 and L6 are 3-phase power line (see attached figure on page 30). The users should connect power in 3-phase 5-wire system.
- b. Control circuit: the control circuit is controlled by 36V power transformed from control transformer TC (see attached figure on page 30), which is easy to control. It can be controlled in electric control box and handle switch. The motor can run simultaneously and independently, which is governed by turning universal switch on the panel of the control box. When universal switch is turned to one side, the single motor running is realized; when handling universal switch in the middle position, both motors run simultaneously.

- c. Circuit of motor brake: the motor brake is installed inside the hood of motor; the voltage is rectified to DC 99V power via half-wave rectifier module.
- d. Emergency stop and overloading protecting circuit: the power is transmitted to motor via general contactor KM1, motor control contactor KM2, KM3 and thermal relay FR1, FR2 and motor socket (see attached figure on page 30). If in any abnormal situation, emergency stop can be executed to ensure safety. That is to press the emergency stop button on the panel of electric control box so that the general contactor KM1 loses power, the motor is power off and the suspended platform stops. Thermal relay can be power-off automatically in case of the motor overloading.
- e. Limit switch and alarm circuit: upper limit stopper is set on the upper working area of the suspended platform. When the limit switch (or travel switch) actuates the limit, the motors will stop running and the suspended platform will stop simultaneously. By the same time, the alarm bell will ring.

3.5.4 Special notice:

- a. If the limit switch is contacted with the top limit stopper, it is necessary to make the suspended platform move downward before pressing the starting button and control button.
- b. If the power supply is off during operation, it is necessary to position the manual descending device by two operators together and then make the suspended platform moved downward to the ground smoothly.
- c. To facilitate the work, L4 and L6 in the electric control box are offered to supply power to lighting and hand-held tools. However, the use of big power consumers such as welding machines and iodine lamps is prohibited so as to prevent the circuit and elements from damage.

3.6 Steel Rope

3.6.1 The steel rope used in hoists for the equipment is special galvanized steel rope.

The structure for ZLP500 and ZLP630 is 4T31/25, diameter is 8.3mm/8.6mm.

The structure for ZLP800 is 6*19W+IWS, diameter is 8.6mm

3.6.2 The maintenance and inspection of steel rope

The steel rope should be kept and maintained in a proper way to prevent corrosion and pollution, and the steel ropes should be regularly inspected for deformation and breakage. The rejection of steel rope is as per the specification of GB5972.

3.6.3 Special notice:

The steel rope must be the steel rope designated by our company.

The steel rope should be replaced in any one of the situations below:

- a. The loosening, twisting, untwisting, or any other deformation and distortion.
- b. The steel rope should be rejected when the rope breaking number within the range of ab spacing reaches 5 (see figure 7 as below). When any corrosion or abrasion on the surface of steel rope, the standard for rejection is reduced further. The percentage of reduction is that the maximum allowable breaking numbers 5 times

the percentage of the corrosion or abrasion on the surface of steel rope to make deduction.



Figure 7: Steel Rope

- c. Obvious corrosion on the steel rope, that is, the concave pit on the surface and the steel rope is loose.
- d. The nominal diameter of steel rope is reduced by 6%, even if there is no twist breakage.
- e. When the abrasion of outer rim of steel rope up to 40% of diameter.
- f. The damage or accumulation incurred by the heat or electric arc.

4. Installations and Adjustment

4.1 The Preparation before Installation

Prior to installation, please check up the number of parts as shown in the packing list. Check the condition of each and all the parts and components.

4.2 Installation of Suspension Mechanism

See attached figure 1: suspension mechanism (page 23) and use the special installing tool — pinch bar if necessary.

4.2.1 Insert the tommy bars into the front base and rear base respectively. Adjust the height of the tommy bars and tighten the bolts to form the front base and rear base. (The height of which should be adjusted with the 1.365~1.925 m range according to the height of parapet).

4.2.2 Lead the front and rear beams into sleeve on front or rear base, position the middle beam between the front and rear beams and tighten the bolts and nuts.

4.2.3 Mount the working steel rope and safety steel rope onto the coupling sleeve of the front beam. Make sure that the ends of the ropes must be clamped well (see section)

4.2.4 Adjust the front beam overhang and fix the upper column with tommy bar with the bolts and make sure that it is not askew.

4.2.5 Adjust the distance between the front and rear bases. Adjust the three beams to make sure that the three beams should be in the same straight line. Care must be taken that the height different between the three beams must not larger than 10 cm. Moreover, it is only allowed that the front is higher than the rear.

4.2.6 Fix the coupling sleeve on the tommy bar of the rear base. Lead one end of the reinforcing steel rope (7m long) into the coupling sleeve of front beam and tighten the rope clamp (see section **4.7.3**). Lead the reinforcing steel rope to the rope sheave on

upper column and the other end through the hole of the close side of the turnbuckle, tighten the rope clamp. Adjust the screw bar of the turnbuckle and tighten the reinforcing steel rope to raise one end of front beam about 3cm.

4.2.7 Place the suspension mechanism to its working position with the reach of front hanger plate out of the working wall space about 60cm. The distance between two front hanger plates of suspension mechanism should be larger than the length of the suspended platform, but not beyond 30cm.

4.2.8 Place the counter weight onto the poles of the rear holder and fix them with bolts and slowly release the steel ropes.

4.3 Installation of Suspended Platform

4.3.1 Put the bottom plate flat on the ground, mount the high and low balustrades, and place the bolts and nuts (also square shims for aluminum platform) in position without tightening them for the time being.

4.3.2 Install the caster wheel on the hoist-mounting frame. Fix the hoist-mounting frame of at the ends of suspended platform; place the bolts and nuts (also square shims for aluminum platform) in position without tightening them for the time being.

4.3.3 Check that the installation of above parts is correct, make sure that the high balustrade in the same line and also the low balustrade.

4.3.4 Tighten the bolts connecting the balustrades and bottom plate, as well as the bolts connecting the balustrades together. Tighten the bolts connecting the balustrades and the hoist-mounting frame. Fix the support pulley at the one side of the low balustrade.

4.4 Installation of Hoists, Safety Locks and Electric Control Box

4.4.1 Fix the hoists on the hoist-mounting frame with pins and M10 bolts: insert the pin into the hole at the low end of the hoist and at the mount frame, insert the M10 bolt into the two holes at the high end of the hoist and at the mount frame.

4.4.2 Install safety lock on the bracket of the hoist-mounting frame and tighten with bolts. Fix the limit switch onto the right position of the safety lock.

4.4.3 Install and hang the electric control box in the middle of high balustrade of the suspended platform.

4.4.4 Insert motor plug and handle switch plug into the power socket of the electric control box. Power plug should be inserted and power cable should be connected based on three-phase five-wire system.

4.5 Adjustment of Rotating Direction of the Motor

Turn on the power supply. Turn the universal switch to one side, press the start button and then press the control button “up”. The rotating direction of the motor should run in clockwise. If not, exchange the two wires. Turn the universal switch to the other side to check the rotating direction of the other motor. Make sure that rotating directions of the motors are correct.

4.6 Connection between Suspended Platform and Suspension

Mechanism

4.6.1 Rope passing of the hoist

Turn the universal switch to the side where the hoist is prepared for rope passing. Insert the working steel rope into the inlet of the hoist after passing between the limiting wheel and the roller of safety lock. And then press the upward button, the hoist will wind automatically to finish the rope passing and positioning of steel rope.

4.6.2 Rope passing of the safety lock

Make the suspended platform rise up until the arm of the safety lock cannot be rose, and then insert the safety steel rope into upper inlet of safety lock.

4.6.3 Place heavy hammer

After the complete of the connection of the working steel rope and safety steel rope, hang the heavy hammer onto the other ends of the ropes.

4.7 Special Notice

4.7.1 The distance between the two suspension mechanisms should be the same with the distance of the two suspension points of the platform, with the error of not larger than 10 cm.

4.7.2 The suggested front beam overhang should be 1.3 m; the suggested distance between the front and rear should be 4.6 m. The counter weight should be placed on the two rear beams on the average basis and fixed with the bolts.

4.7.3 The fixing method at the end of steel rope should be in accordance with the requirements of the standard GB5976-86 (see figure 8 as below). U bolt is fixed on the rear portion of steel ropes; clamp is fixed on the working section of steel ropes, which cannot be mixed up. The steel rope clamp cannot be alternately arranged on the steel rope, and the correct clamping method is as follows:

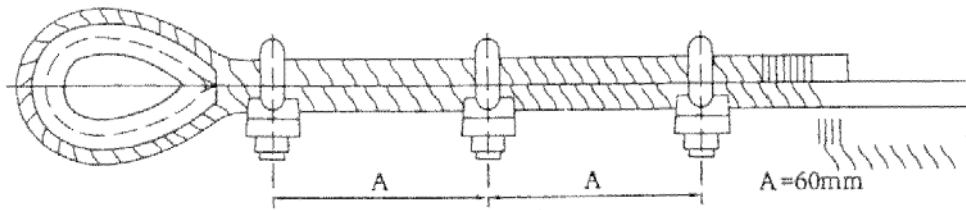

Figure 8: The Correct Clamping Method

- a. Quantity of the clamps: 3 pieces (at least);
- b. Arrangement of the clamps (see figure 8 above);
- c. The distance between the clamps is 60 mm;
- d. Tightening of the clamp: the first clamp should be close to the rope ring and tightened. Care must be taken that it is not allowed to damage the steel rope when tightening, and then make the second and third clamps. It is necessary to make the clamps tightened again after the steel rope is loaded one or two times.

4.7.4 Care must be taken that the steel ropes must not be damaged, deformed or twisted.

4.7.5 The hoist must be fixed with the pins and bolts.

4.7.6 Make sure that the plugs of the two motors and the control button be inserted into the sockets of the control box correctly.

4.7.7 The power supply, connected with the control box, should have the null and earth lines and the control box should be ground contacted reliably.

4.7.8 Make sure that the connection of the steel rope with the hoist is in normal, otherwise, stop connection for check.

4.7.9 The remaining steel rope should be placed in order and bounded well.

4.7.10 The four heavy hammers must be hung onto the lower ends of the working steel rope and safety steel rope respectively.

5. Operation

5.1 Checking and Adjusting after Installation

5.1.1 Check if the connections are correct, the steel ropes are not damaged, the clamping are correct, the nuts are tightened, and the front beam overhang is in accordance with the standard. Make sure that the moment of force of the stability of the suspension mechanism is over two times of the overturning moment.

5.1.2 Check if the wiring is correct. The voltage of power should be within the range of $\text{___V} \pm 5\%$. After the power is connected, push the testing button on the power leakage breaker, and power leakage breaker should work swiftly. Close the door of electric control box, and inspect if handle switch, universal switch and motor is normal.

5.1.3 Checking electromagnetic brake:

- a. The spacing between the armatures and the electromagnetic disk should be within 0.8-1.0 mm (see figure 9).
First, loose inner hexagon screw (1),

then adjust the spacing by turning hollow screw (4). Finally, tighten inner hexagon screw (1).

- b. Power on to check the operation of electromagnetic armature, the armature must separate with friction disc completely after being absorbed, and no clog after power is off. The armature should press the spring disc completely under the force of spring.

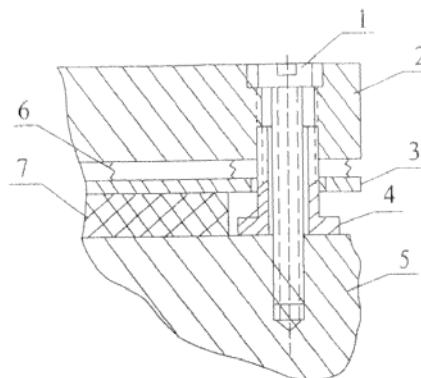

Figure 9: Electromagnetic Brake

- 1. Inner hexagon screw
- 2. Electromagnetic disk
- 3. Armature
- 4. Hollow screw
- 5. Motor cover
- 6. Spring
- 7. Friction disk

5.1.4 Checking safety lock: move the suspended platform upward about 1-2 m and make its one end inclined about $3^{\circ} \sim 8^{\circ}$, the safety lock should be actuated to lock the safety steel rope.

5.1.5 Make the suspended platform upward and downward 3-5 times for about 3-5 m travel and check:

- a. The noise of the hoist should be normal and the electromagnetic brake will be actuated reliably.
- b. Press emergency stop button or pull the limit switch, the suspended platform will stop moving immediately.
- c. Make the suspended platform horizontal, if necessary.

5.1.6 Checking manually descending: move the suspended platform upward for about 3-5 m and stop it. Pull the manual descending device, the suspended platform can move downward smoothly.

5.1.7 Adjustment of the upper limit stopper: move the suspended platform upward to the highest position. Fix the limit stopper and adjust the location of the limit switch and make sure that the limit switch will be actuated normally.

5.1.8 Rated load testing: The rated load should be evenly distributed on the working platform. In the operating process no abnormal sound, and when stopping no sliding movement. The safety lock should lock the safety steel rope flexibly and reliably when the platform is in tilting.

5.2 Operation Procedure

5.2.1 Turn on the power supply.

5.2.2 Press the starting button.

5.2.3 Double hoists operation: turn universal switch to the middle position and press the control button.

5.2.4 Single hoist operation: turn universal switch to the side of the operating hoist and press the control button.

5.2.5 After the work completed, cut off the power supply and make sure the control box is locked.

5.3 Safety Operation Regulations

The suspended access equipment is special equipment operated at the certain height, so it is very important to pay more attention to the safety operation. After installation, it is necessary to follow the procedures of 5.1 last page for checking and adjusting. Besides, the following safety operation regulations should be followed:

5.3.1 The suspended access equipment should only be operated and maintained by qualified personnel with adequate technical training.

5.3.2 The operators should read the operation manual and check the equipment carefully before operation strictly follow the safety regulations and “Daily Check Items” (see section 7.2) during the operation and maintenance of the equipment.

5.3.3 The operators should wear safety helmets and should be fastened with rope lifeline with the self-lock device. Moreover, the rope lifeline should be fixed independently on the attachment over the operating area.

5.3.4 It is not allowed to use the equipment overloaded or with troubles (the rated weight including the weight of operators). The load should be evenly distributed on the platform. The loaded weight must be decreased as the working height, the front beam overhang or the distance between the front and rear holders change. Furthermore, the loaded weight must be decreased further if the wind force is stronger. Make sure that the moment of force of the stability of the suspension mechanism is over two times of the overturning moment.

5.3.5 It is not suggested to install the platform over the rated length or use the two platforms together. And it is also not allowed to assembly the suspended platform with the parts and elements from different manufactories.

5.3.6 The limit switch, emergency stop button, electromagnetic brake and manual descending device should be sensitive and reliable.

- a. When the platform is in its normal operation, it is prohibited to manually break the motors or safety lock, so as to prevent any accident from happening.
- b. The emergency stop button is the self-lock one, it is necessary to be rotated in clockwise to make the button out when reset.
- c. It is necessary to press the starting button to move the platform after the limit switch or the emergency stop button is pressed.
- d. When the limit switch is activated, the operation of platform will automatically halt and the alarm bell will ring. Under this circumstances, lower the platform promptly to have the limit switch be away from the limit stopper.

5.3.7 During operation of platform, the operator should keep an eye on the platform’s operation condition and promptly shoot any hidden trouble possibly leading to accidents.

5.3.8 The platform should be adjusted promptly if it is tilting and the height difference of two ends should be no higher than 15cm. And otherwise, it will affect the operation of the safety lock.

5.3.9 It is not allowed to use ladders, boxes, or other tools to obtain increased height. Never use additional extensions to exceed the permissible length of the platform.

5.3.10 It is not allowed to make use the platform as the elevator for people or goods

and also it is not allowed to mount any hanging device in the platform.

5.3.11 Once the hoist is blocked during operation, it is not allowed to move the platform forcedly. Fix the platform first and make sure it is safety, then check and eliminate the troubles.

5.3.12 In case of working steel rope breakage during operation, the personnel in the platform should keep calm and leave the platform under the prerequisite of ensured safety. After maintenance and repair personnel enters the platform, the first thing to do is to take anti-dropping measures by having the clamp of safety steel rope hold the platform or by fastening the platform with the steel rope secured on the building roof. Then, pull the replacing steel rope through the hoist, and press the up button to have the platform move upward. If the suspended access equipment works normally, release the safety lock cautiously, detach the fixing steel rope and lower the platform down to the ground. It will not be put into operation again until it passes the stringent inspection.

5.3.13 In case of power break during operation shut down the power first. If it is necessary to have the suspended platform lowered back onto the ground, operate manual descending device to have the platform lowered smoothly onto the ground.

5.3.14 Site environment:

- a. No high voltage line within the 10 meters;
- b. It is not allowed to use the equipment in thunderstorm, fog or the wind of grade 5 (wind speed 8.3m/s) or higher;
- c. Make sure that the welding spark will not affect or damage the steel rope;
- d. Temperature required: -20°C~+40°C;
- e. Error of the voltage: $\pm 5\%$.

5.3.15 The suspended access equipment should avoid contacting corrosive gas and liquid. If there is no alternative available, anti-corrosion and segregation measures should be taken in its operation.

5.3.16 Cut off the power supply, lock the control box and clean the equipment after completion of the operation. It is not allowed any foreign, dirty matter or water entering into the motor, safety lock, electromagnetic brake and control box.

5.3.17 The working steel rope and safety steel rope should not be bent and should be prevented from the contamination of mortar and other foreign materials. They should be replaced as required by the operation manual in case of cracking, breaking, peeling, distortion, flossing and corrosion. The safety steel rope should be prevented from contacting grease or oil.

5.3.18 The safety lock should be checked and its moving parts should be lubricated regularly during its service life and it should not be dismantled without authorization.

5.3.19 Special attention should be paid to mark limit effective of the safety lock. When the steel rope is removed from platform, it should be winded to form a bundle and be stored properly.

6. Common Failures and Troubleshooting

| Troubles | Analysis of causes | Troubleshooting | Remarks |
|---|---|---|-----------|
| Suspended platform slides down in static condition | <ol style="list-style-type: none"> 1. Motor electromagnetic brake fails. 2. The spacing between brake and armature is over too big. | <ol style="list-style-type: none"> 1. Replace electromagnetic brake. 2. Adjust the space. | See 5.1.3 |
| Suspended platform cannot stop in ascending | The main contact point of AC contactor disengages. | Press emergency stop button or pull the limit switch to stop the moving of the platform, replace the contactor. | |
| | Control button fails. | Press emergency stop button or pull the limit switch to stop the moving of the platform, replace the control button. | |
| Suspended platform cannot stop in descending | The main contact point of AC contactor disengages or the control button fails. | Press emergency stop button or pull the limit switch to stop the moving of the platform, replace the contactor or control button. | |
| | <p>The electromagnetic brake is out of order:</p> <ol style="list-style-type: none"> 1. The space between the electromagnetic disk and the armature is too big. 2. Too small contact area between the friction disk and the armature. 3. Slipping between the friction disk and the armature because of the water or oil. 4. The steel rope is slipping in the hoist. | <ol style="list-style-type: none"> 1. Adjust the space. If it is can't be done, replace the brake disk. 2. Check if the space between the friction disk and the armature is well-distributed; otherwise, replace the disk or the armature. 3. Clean. 4. Repair the hoist. | See 5.1.3 |
| Suspended platform cannot ascend and descend | <p>Power supply is abnormal:</p> <ol style="list-style-type: none"> 1. Leakage breaker disengages. 2. Phase lacking. | <ol style="list-style-type: none"> 1. Check to see if any leakage, and take preventive measures. 2. Check if the 3-phase power is normal and reconnect. | |

| | | | |
|--|--|---|---|
| | <p>Failure of control line:</p> <ol style="list-style-type: none"> Control transformer or control button damaged. Thermal overload relay breaks or damages. Universal switch not in good contact. | <ol style="list-style-type: none"> Replace. Wait 3-5 minutes before restarting or replacing the thermal overload relay. Replace. | |
| | <p>The steel rope is blocked in the hoist.</p> | <p>Fix the platform and examine & repair hoist.</p> | <p>It is not allowed to restart the platform forcedly</p> |
| Suspended platform tilt | <ol style="list-style-type: none"> Sensitivity difference in motor brake. Difference in motor rotating speed, and hoist rope pulling. | <ol style="list-style-type: none"> Adjust the spacing of motor brake. Check the rope pressing device of hoist or replace rope pressing device or replace motor with incorrect rotating speed. | |
| | <p>Uneven in the load of suspended platform.</p> | <p>Adjust the load of suspended platform.</p> | |
| Hoist cannot actuate suspended platform | <p>The electromagnetic brake is not actuated:</p> <ol style="list-style-type: none"> Rectifier damaged. No input voltage. | <ol style="list-style-type: none"> Replace the rectifier. Check and adjust. | <p>Input voltage: AC220 V and output voltage: DC99 V</p> |
| | <p>Low voltage of the power supply.</p> | <p>Check and adjust the voltage.</p> | |
| | <p>Damage of hoist.</p> | <p>Check and repair the hoist.</p> | |
| Abnormal noise of the motor or the motor is hot | <p>Operation lacking phases.</p> | <p>Check the power supply.</p> | |
| | <p>Lower or higher voltage.</p> | <p>Adjust the voltage.</p> | |
| | <p>Bearing damaged.</p> | <p>Replace.</p> | |
| Safety lock slip or locking angle is too big | <p>Oil dust on the safety steel rope</p> | <p>Clean or replace the steel</p> | |
| | <p>Problem wit rope clip.</p> | <p>Replace the clip.</p> | <p>Replace by manufactory</p> |
| | <p>Sluggish motion in safety lock.</p> | <p>Replace torsion spring of safety lock.</p> | |

7. Maintenance

The daily maintenance and check, before operation of the equipment, will be done by the operators and check periodically by the qualified personnel. The maintenance and the check should be recorded.

7.1 Daily Maintenance

7.1.1 Safety lock

- a. Cleaning the surface;
- b. Cleaning the surface of the steel rope and clear out the rust;
- c. Prevent the water and dirty matter from entering the lock.

7.1.2 Hoist

- a. Cleaning the surface;
- b. Cleaning the surface of the electromagnetic brake and the end cover of the motor by removing the cover of the motor;
- c. Cleaning the surface of the steel rope and clear out the rust;
- d. Prevent the water and dirty matter from entering the hoist and motor.

7.2 Daily Check

- a. Reliability of the safety lock;
- b. Emergency stop and limit switch;
- c. Reliability of the electromagnetic brake;
- d. Sensitive of the manual descending device;
- e. Steel rope, rope clamp and connections;
- f. Making the suspended platform move upward and downward 3-5 times with the travel of about 3-5 meters;
- g. Following the “Daily Check Items” (see attached table 2), check two times every day (morning and afternoon). It is not allowed to use the suspended platform with any troubles.

7.3 Check Periodically

The safety lock must be re-calibrated in six month from the date of the delivery by the manufacturer; and the hoist must be checked by the qualified person. Generally, the equipment should be checked at an interval of 2 months depending on the application condition and the working period. After the end of use of entire machine, a thorough keeping and examination should be done.

7.3.1 Hoist:

- a. Replace the oil in the gear reducer: No. 32 machine oil (LTD8), No. 18 hyperbola gear oil (LTD5 and LTD6.3), quantity: 0.8 kg; first replace in 20-30 days, then replace in one or two months intervals. Check the wear-out condition of the worm and gear.
- b. Clearing out the dirty matter by removing the cover of the hoist; cleaning the gear and replace the grease; check the wear-out condition of the bearing assembly, guide roller, steel ring and press pan.
- c. Cleaning the electromagnetic by removing it; check the wear-out condition of the armature and the brake disk. Replace if the armature is deformed or the thickness of the brake disk is less than 10 mm.

7.3.2 Safety lock: check if the arm action of the lock and the rotation of the roller are sensitive.

7.3.3 Electric control box: the isolated resistance should be less than $2M \Omega$; check the electric elements and the connecting wire; replace the elements, if necessary, based on the diagram; check the system condition with power on.

7.3.4 Check if the working steel rope and safety steel rope are in good condition.

7.3.5 Check if the suspended platform and the suspension mechanism are deformed or damaged; if there is any crack and fracture in welding of the structure. Repair or reject if necessary.

8. Storage, Packing and Transportation

The equipment should be stored in the dry and ventilating storehouse to prevent it from rusting. It is necessary to make the maintenance if it is stored for one-year period. The hoist, safety lock and the electric control box should be packed separately. The steel ropes should be bounded and packed for transportation. Care must be taken that the bottom plate of the platform, balustrades, mount frame for hoist and the suspension mechanism should not be deformed when loading and transportation.

9. Documents and Tool

9.1 Documents attached

- | | |
|-----------------------------------|----------|
| a. Packing list | one copy |
| b. Operation manual | one copy |
| c. Quality inspection certificate | one copy |

9.2 Tools

| | |
|-----------|-----------|
| Pinch bar | one piece |
|-----------|-----------|

10. Attached Table and Figure

Attached figure 1: Suspension Mechanism

Attached Figure 2:LTD5& LTD6.3 Hoist Structural Diagram

Attached Figure 3: LTD5& LTD6.3Hoist Exploded View

Attached Figure 4: LTD8 Hoist (A)

Attached Figure 5: LTD8 Hoist (B)

Attached Figure 6: Electric Control Schematic Diagram

Attached Figure 7: Electric Wiring Diagram

Attached Table 1: List of Fragile Parts

Attached Table 2: Daily Check Items

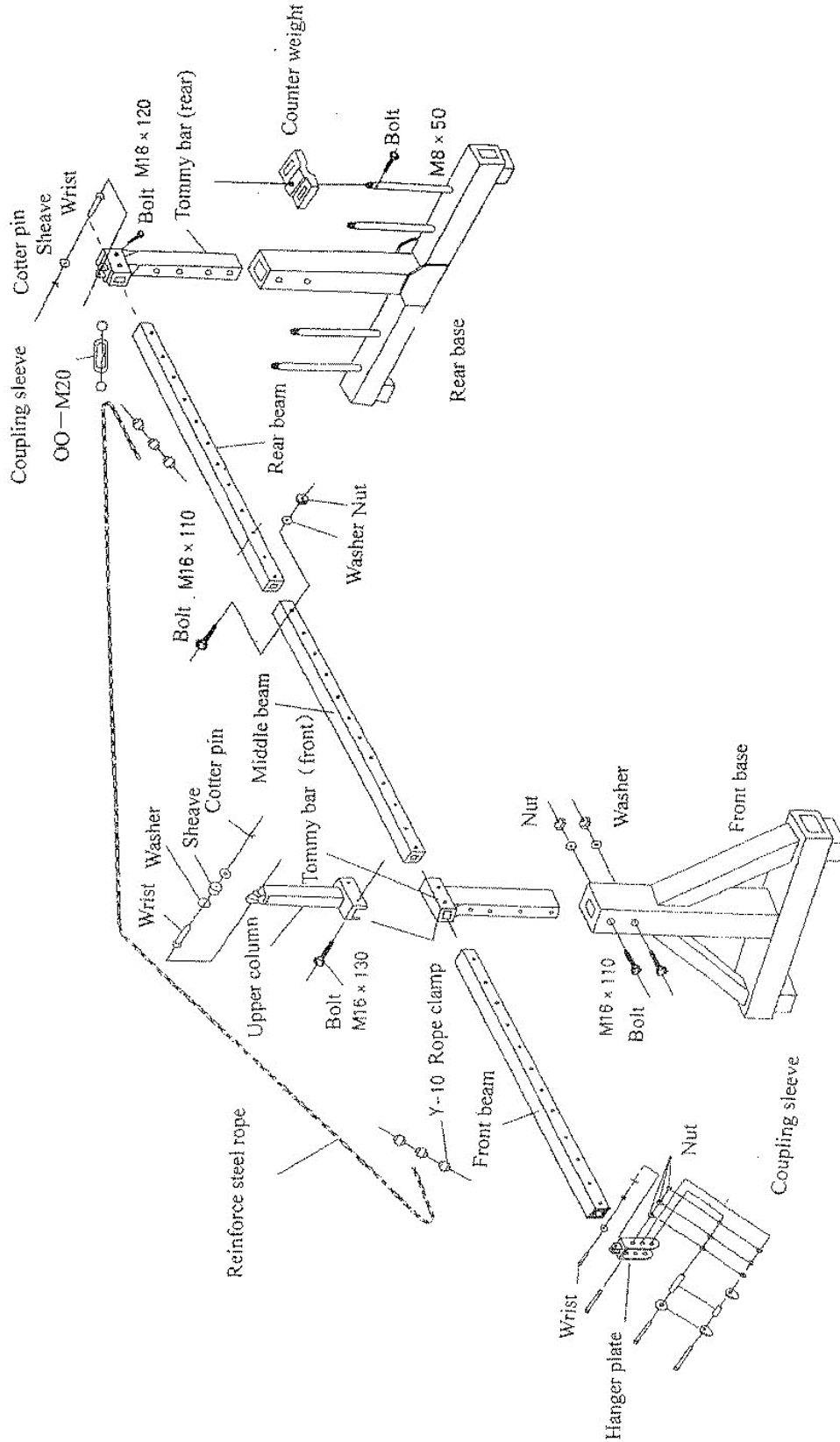

Attached figure 1: Suspension Mechanism

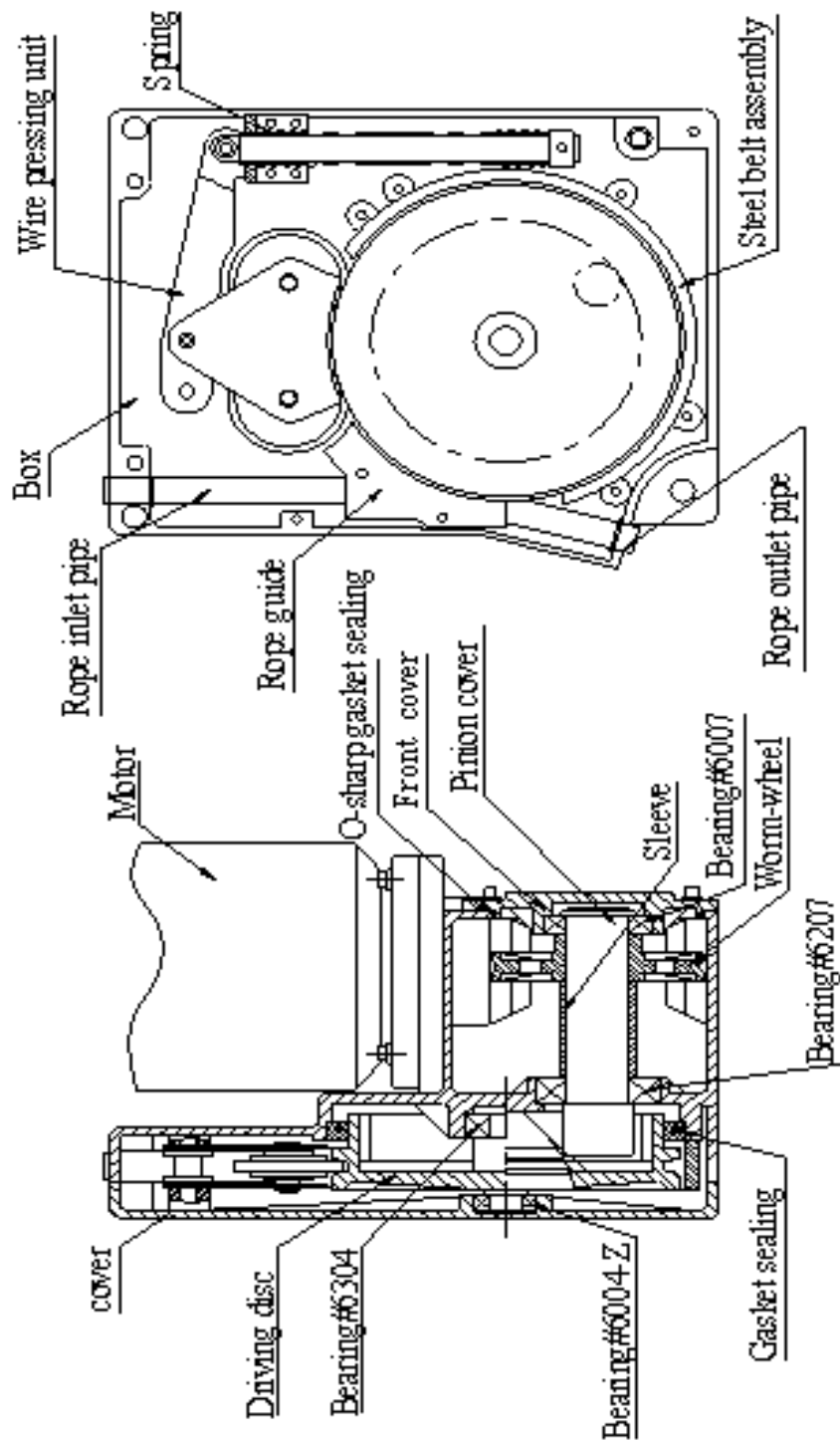

Attached Figure 2: LTD5 & LTD6.3 Hoist Structural Diagram

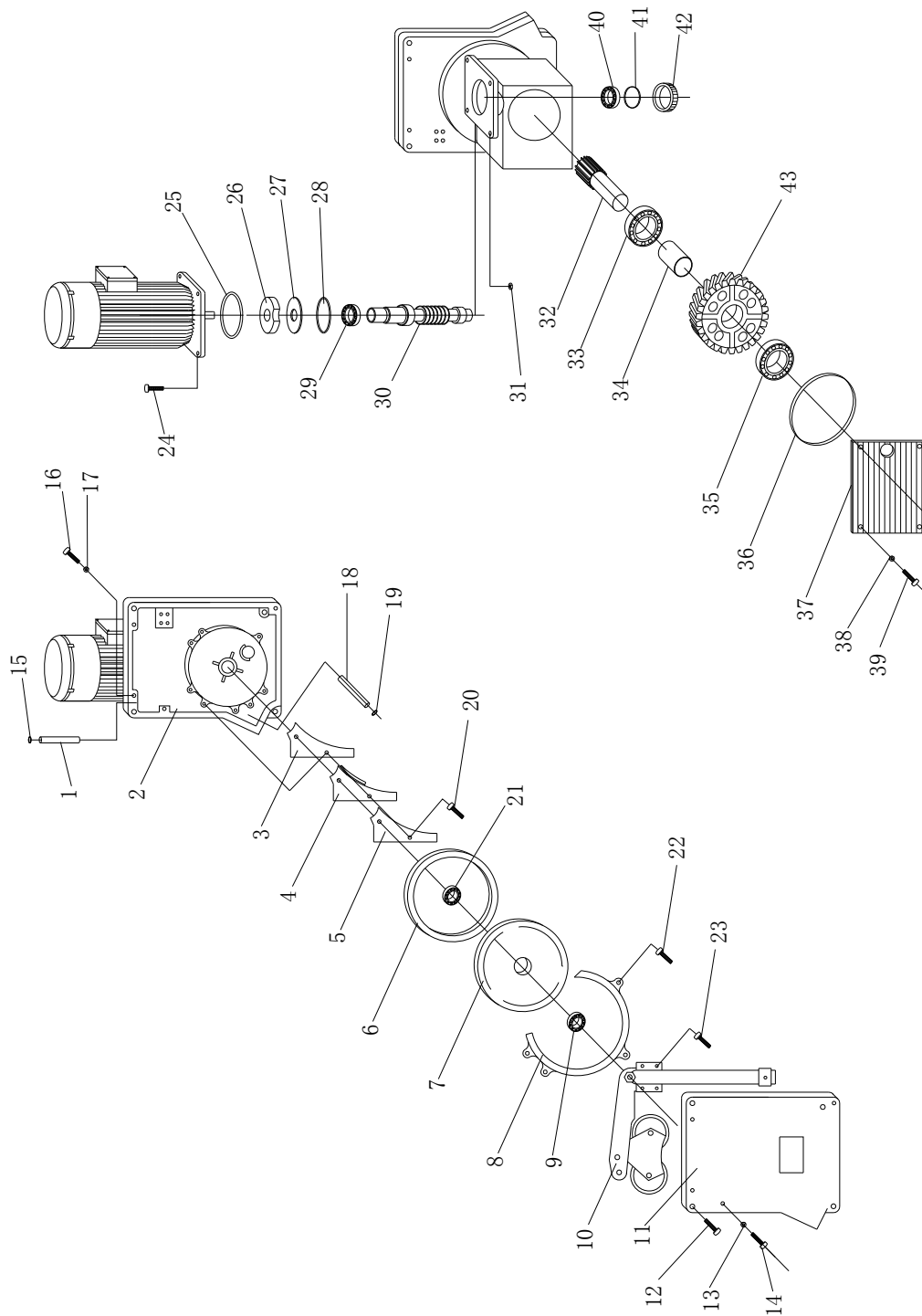

Attached Figure 3: LTD5 <D6.3 Hoist Exploded View

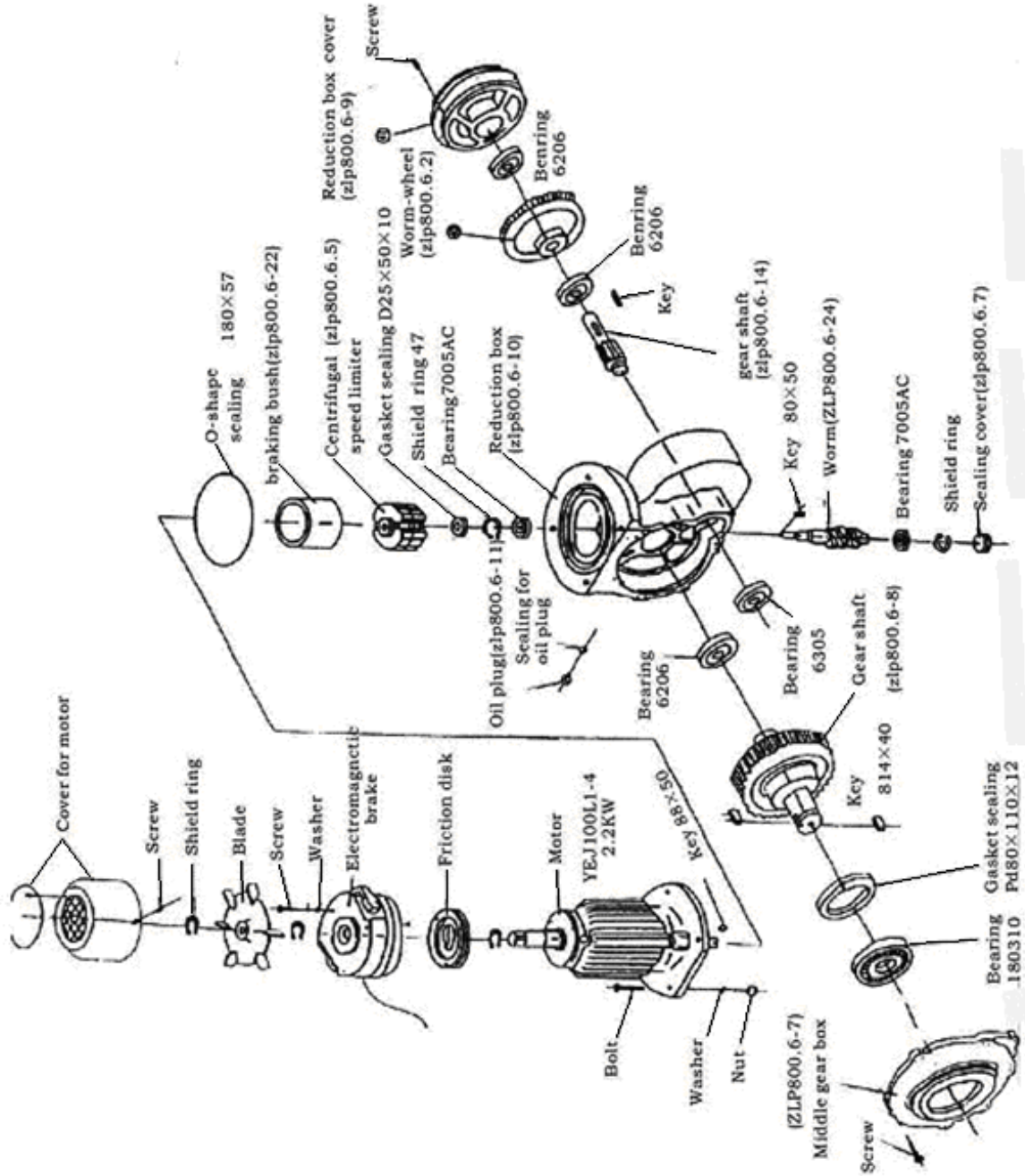

Attached Figure 4: LTD8 Hoist (A)

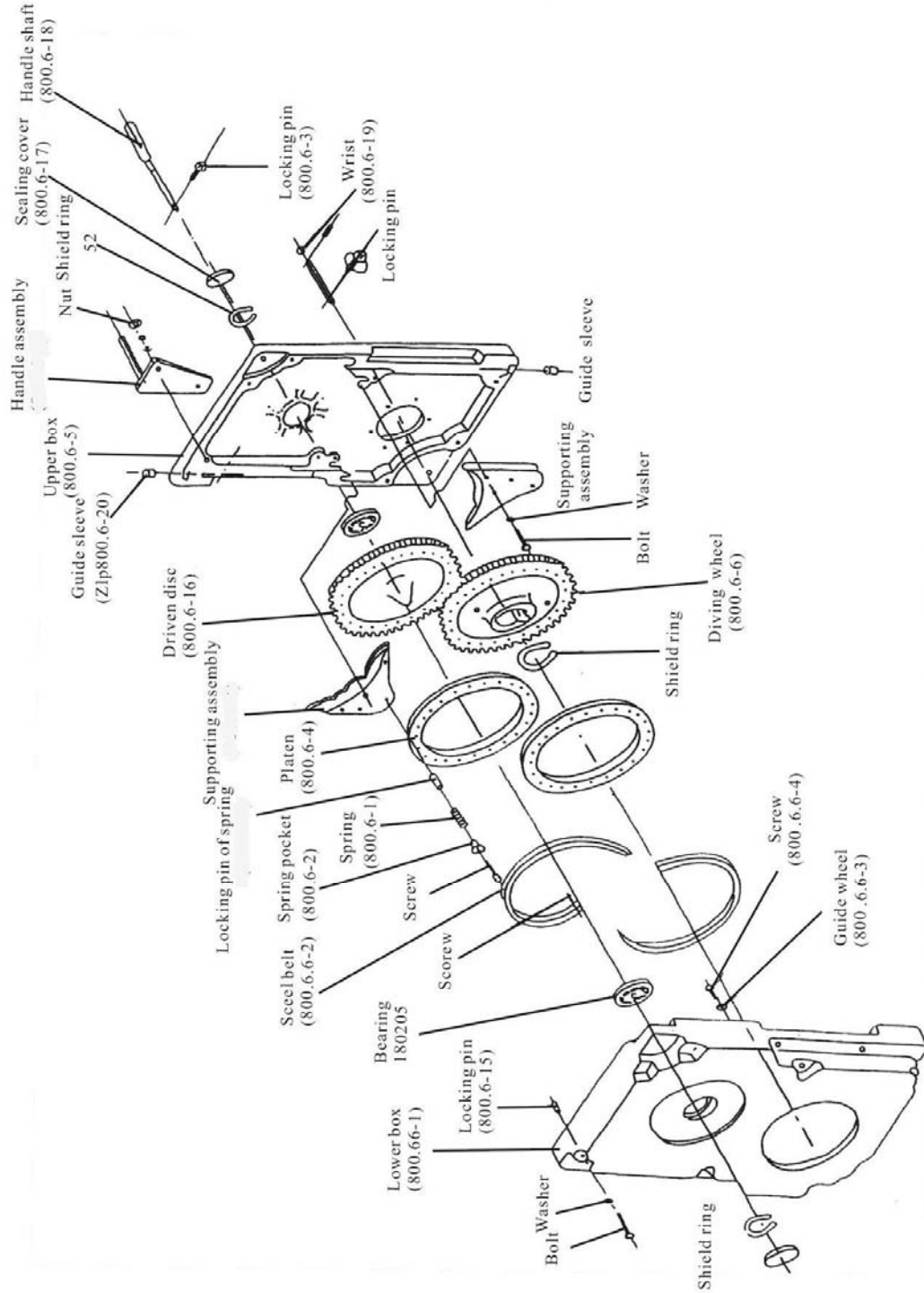

Attached Figure 5: LTD8 Hoist (B)

Components of LTD5 (See Attached Figure 2 & 3)

| No. | Name | Specification | Quantity | No. | Name | Specification | Quantity |
|-----|--------------------------|---------------|----------|-----|---------------------------|---------------|----------|
| 1 | Rope inlet pipe | ZLP5008.1-12 | 1 | 23 | Screw | M6×30 | 4 |
| 2 | Box | ZLP5008.1-4 | 1 | 24 | Bolt | M8×35 | 4 |
| 3 | Base plate of rope guide | ZLP5008.4-2 | 1 | 25 | O-shape gasket sealing | 35510460 | 1 |
| 4 | Rope guide | ZLP5008.4-1 | 1 | 26 | Centrifugal Speed limiter | | 1 |
| 5 | Cover of Rope guide | ZLP5008.4-3 | 1 | 27 | Gasket sealing | B47×25×7 | 1 |
| 6 | Gasket sealing | B230×200×15 | 1 | 28 | Shield ring | GB893.1-86-37 | 1 |
| 7 | Driving disc | ZLP5008.1-11 | 1 | 29 | Bearing | #6005-2Z | 1 |
| 8 | Steel belt assembly | ZLP5008.1-8 | 1 | 30 | Worm | ZLP500B.1-1 | 1 |
| 9 | Bearing | #6304-Z | 1 | 31 | Nut | M8 | 4 |
| 10 | Wire pressing unit | | 1 | 32 | Pinion shaft | ZLP500B.1-7 | 1 |
| 11 | Cover | ZLP5008.1-5 | 1 | 33 | Bearing | #6007 | 1 |
| 12 | Bolt | M10×90 | 2 | 34 | Sleeve | ZLP500B.1-9 | 1 |
| 13 | Washer | Φ6 | 3 | 35 | Bearing | #6207 | 1 |
| 14 | Screw | M6×35 | 3 | 36 | O-shape gasket sealing | 35513600 | 1 |
| 15 | Shield ring | GB894.2-86-18 | 1 | 37 | Front cover | ZLP500B.1-11 | 1 |
| 16 | Screw | M6×70 | 3 | 38 | Washer | Φ6 | 4 |
| 17 | Washer | Φ6 | 3 | 39 | Screw | M6×30 | 4 |
| 18 | Rope outlet pipe | ZLP5008.1-13 | 1 | 40 | Bearing | #6303-2Z | 1 |
| 19 | Shield ring | GB894.2-86-18 | 1 | 41 | Shield ring | GB893.1-86-37 | 1 |
| 20 | Screw | M6×45 | 2 | 42 | Sealing cover | ZLP500B.2-2 | 1 |
| 21 | Bearing | #6304 | 1 | 43 | Worm-wheel | ZLP500B.1-10 | 1 |
| 22 | Screw | M6×25 | 4 | | | | |

Components of LTD6.3 (See Attached Figure 2 & 3)

| No. | Name | Specification | Quantity | No. | Name | Specification | Quantity |
|-----|--------------------------|---------------|----------|-----|---------------------------|---------------|----------|
| 1 | Rope inlet pipe | ZLP6308.1-12 | 1 | 23 | Screw | M6×30 | 4 |
| 2 | Box | ZLP6308.1-4 | 1 | 24 | Bolt | M8×35 | 4 |
| 3 | Base plate of rope guide | ZLP6308.4-2 | 1 | 25 | O-shape gasket sealing | 35510460 | 1 |
| 4 | Rope guide | ZLP6308.4-1 | 1 | 26 | Centrifugal speed limiter | | 1 |
| 5 | Cover of Rope guide | ZLP6308.4-3 | 1 | 27 | Gasket sealing | B47×25×7 | 1 |
| 6 | Gasket sealing | B230×200×15 | 1 | 28 | Shield ring | GB893.1-86-37 | 1 |
| 7 | Driving disc | ZLP6308.1-11 | 1 | 29 | Bearing | #6005-2Z | 1 |
| 8 | Steel belt assembly | ZLP6308.1-8 | 1 | 30 | Worm | ZLP6308.1-1 | 1 |
| 9 | Bearing | #16304-Z | 1 | 31 | Nut | M8 | 4 |
| 10 | Wire pressing unit | | 1 | 32 | Pinion shaft | ZLP6308.1-7 | 1 |
| 11 | Cover | ZLP6308.1-5 | 1 | 33 | Bearing | #6007 | 1 |
| 12 | Bolt | M10×90 | 2 | 34 | Sleeve | ZLP6308.1-9 | 1 |
| 13 | Washer | Φ6 | 3 | 35 | Bearing | #6207 | 1 |
| 14 | Screw | M6×35 | 3 | 36 | O-shape gasket sealing | 35513600 | 1 |
| 15 | Shield ring | GB894.2-86-18 | 1 | 37 | Front cover | ZLP6308B.1-11 | 1 |
| 16 | Screw | M6×70 | 3 | 38 | Washer | Φ6 | 4 |
| 17 | Washer | Φ6 | 3 | 39 | Screw | M6×30 | 4 |
| 18 | Rope outlet pipe | ZLP6308.1-13 | 1 | 40 | Bearing | #10003-2Z | 1 |
| 19 | Shield ring | GB894.2-86-18 | 1 | 41 | Shield ring | GB893.1-86-37 | 1 |
| 20 | Screw | M6×45 | 2 | 42 | Sealing cover | ZLP6308B.2-2 | 1 |
| 21 | Bearing | #10004 | 1 | 43 | Worm-wheel | ZLP6308B.1-10 | 1 |
| 22 | Screw | M6×25 | 4 | | | | |

Components of LTD8

Please see details in the attached figure4 and figure5.

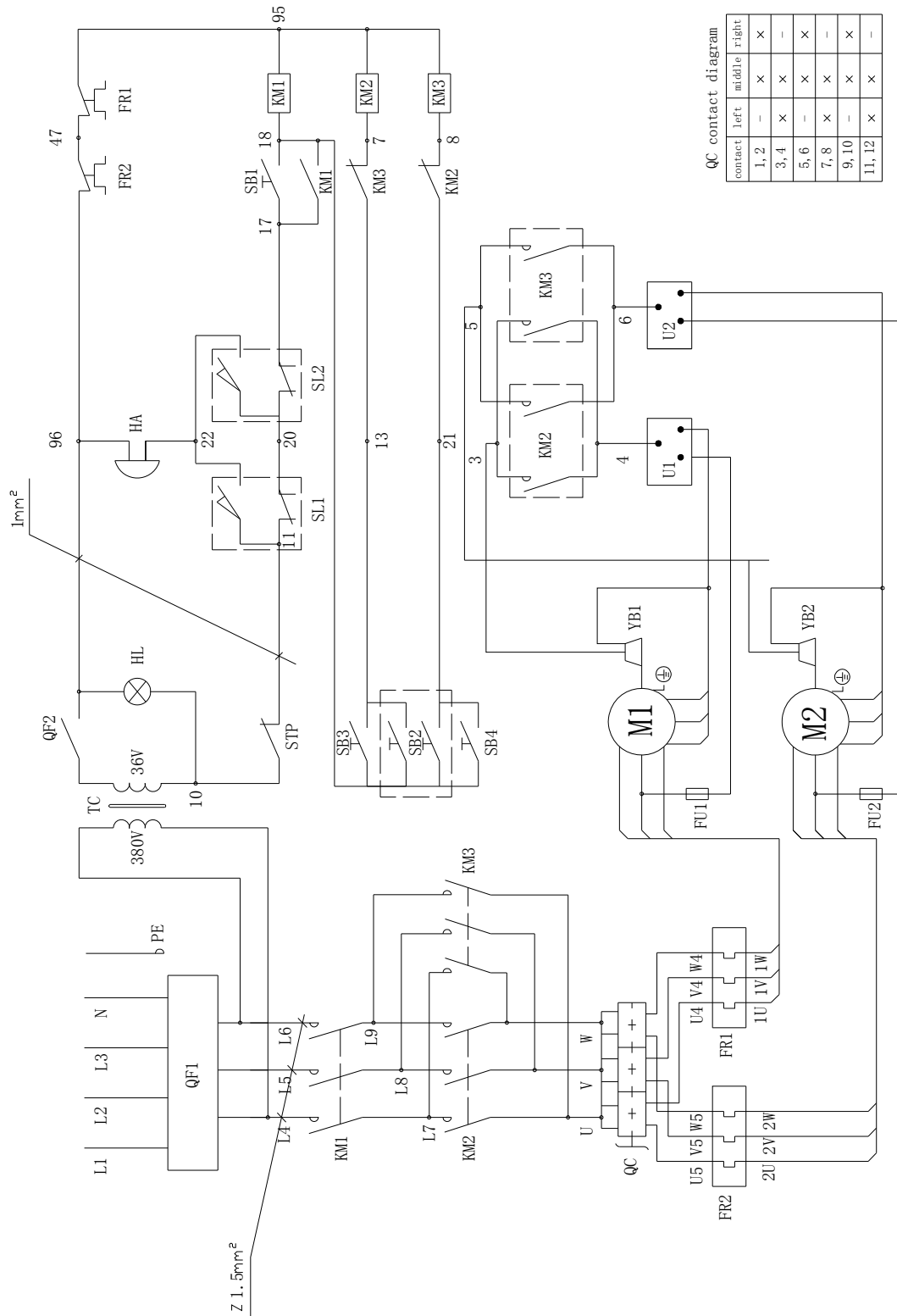

Attached Figure 6: Electric Control Schematic Diagram

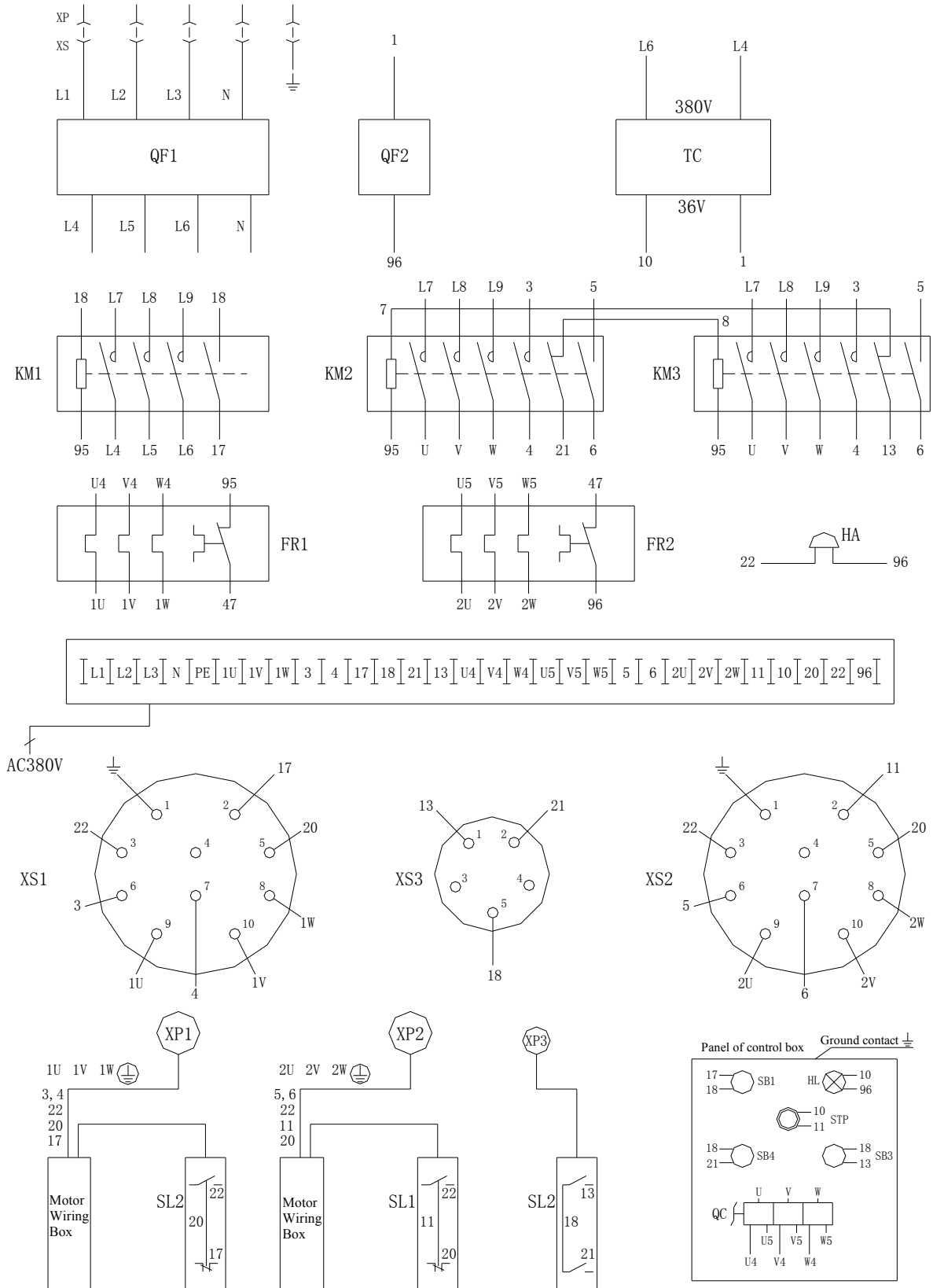

Attached Figure 6: Electric Control Schematic Diagram

| No. | Item | Installation part |
|------------|---------------------------|--------------------------------|
| 1 | Steel rope | Working and safety steel rope |
| 2 | Braking friction disc | Electromagnetic Brake of Motor |
| 3 | Armature | Electromagnetic Brake of Motor |
| 4 | Rectifier module | Junction box of Motor |
| 5 | Centrifugal speed limiter | Hoist |
| 6 | Rope pressing unit | Hoist |
| 7 | Rope guide | Hoist |
| 8 | Steel belt assembly | Hoist |
| 9 | Rope inlet pipe | Hoist |
| 10 | Rope outlet pipe | Hoist |
| 11 | Sleeve plate | Safety lock |
| 12 | Rope clip | Safety lock |

Attached Table 1: List of Fragile Parts

| Item | Contents | Result | Marks | Item | Contents | Result | Marks |
|---|---|--------|-------|------------------------------------|---|--------|-------|
| Steel rope | Any damage (broken, deformation, slacking or bending) | | | Hoist | Connections with the mount frame | | |
| | Dirty with oil | | | | Oil leakage | | |
| | Rust and wear-out | | | Suspended platform movement | Any abnormal noise when the platform is moving upward and downward for 3-5 m in 3 times | | |
| | Clamp slacking | | | | Horizontal level | | |
| Suspended mechanism | Counter weight lose or damage | | | Electric control box | Plug and socket connection | | |
| | Connections | | | | Electric cable | | |
| | Location | | | | Indicating lamp of the power supply | | |
| Suspended platform | Connections | | | | Actuation of the universal switch | | |
| | Tube damaged or rust | | | | Actuation of the AC contactor | | |
| | Crack in welding | | | Actuation of the limit switch | | | |
| Safety lock | Lock rope is reliable if inclined | | | Actuation of the emergency stop | | | |
| | Sensitive in action | | | Comments and suggestions: | | | |
| Electro-magnetic brake | Spacing | | | | | | |
| | Blocked or not | | | | | | |
| | Brake reliable | | | | | | |
| | Slipping down manually | | | | | | |
| <p>Note: 1. The “Result” column: “√” means good and “×” means trouble. 2. If the “Result” column is trouble, “Marks” column: “☆” means to be repaired immediately; “Δ” means to be repaired at the definite period; and “○” means to be rejected. 3. The movement of the suspended platform should be checked after the completion of the above items</p> | | | | | | | |

Equipment No.

Checked by:

Date:

Attached Table 2: Daily Check Items